

Calculus: Disk/Washer and Shell Methods

In calculus, the disk/washer and shell methods are two separate integration processes used to find the volume of a solid of revolution. A solid of revolution is defined as a three-dimensional shape created when an area, bounded by curves, axes, and/or lines, is rotated around an axis of revolution. With the disk/washer method, the area is made up of a series of stacked disks. With the shell method, the area is made up of nested cylindrical shells. This handout explains the disk/washer and shell methods and includes several examples of how they are used.

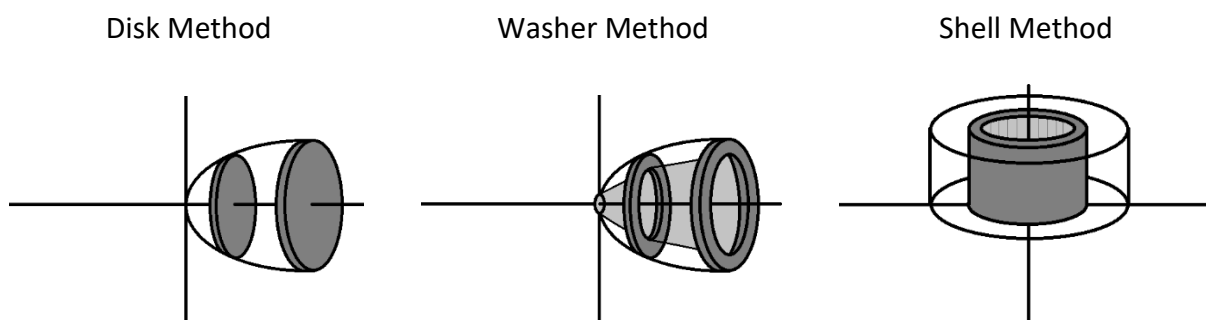

General Steps for Both the Disk/Washer and Shell Methods

1. Identify the required integration equation.
2. Find the upper and lower integration limits.
3. Determine the function order (if necessary).
4. Plug the function(s) and limits into the integration equation.
5. Solve the integral.

The Disk/Washer Method

The disk/washer method involves finding the volume of a solid by cutting it into slices. If the slice is completely solid (common when there is a single function), a disk equation (V_d) should be used. If the slice has a hole or space to be excluded from the volume calculation (common when there is more than one function), a washer equation (V_w) should be used. These equations are based on the area of a disk equation, $A = \pi r^2$. The table on the next page provides a summary of the equations for the disk/washer method with respect to the axis of revolution and shows what the function variable (x or y) needs to be in each case. The axis of revolution can be the x -axis, y -axis, or a line, such as $y = n$ where n is a value greater than or less than zero.

Method	Axis of Revolution	Volume (V) Integration Equation
Disk/ Washer	x-axis	$V_d = \pi \int_a^b f(x)^2 dx$ OR $V_w = \pi \int_a^b f(x)^2 - g(x)^2 dx$
	$y = n$	$V_d = \pi \int_a^b f(n - x)^2 dx$ OR $V_w = \pi \int_a^b f(n - x)^2 - g(n - x)^2 dx$
	$y = -n$	$V_d = \pi \int_a^b f(x + n)^2 dx$ OR $V_w = \pi \int_a^b f(x + n)^2 - g(x + n)^2 dx$
	y-axis	$V_d = \pi \int_c^d f(y)^2 dy$ OR $V_w = \pi \int_c^d f(y)^2 - g(y)^2 dy$
	$x = n$	$V_d = \pi \int_c^d f(n - y)^2 dy$ OR $V_w = \pi \int_c^d f(n - y)^2 - g(n - y)^2 dy$
	$x = -n$	$V_d = \pi \int_c^d f(y - n)^2 dy$ OR $V_w = \pi \int_c^d f(y - n)^2 - g(y - n)^2 dy$

Example 1

Find the volume of the solid generated by revolving the area bounded by the following equations about the x-axis using the disk/washer method.

$$y = x^{1/4}, y = x$$

Step 1: Identify the required integration equation.

When the disk/washer method is used with the x-axis as the axis of revolution, the function variable is x and the integral's upper and lower limits will be "a" and "b." This correlates to the first equation set in the table. Two equations were provided, so the washer equation should be used.

$$V_w = \pi \int_a^b f(x)^2 - g(x)^2 dx$$

Step 2: Find the upper and lower integration limits.

The smaller limit will be “a” and the larger limit will be “b.” Use a graphing calculator to locate the intersection points or set the two equations equal to each other to find where the two graphs intersect.

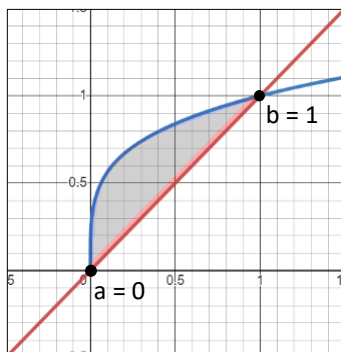

$$x^{1/4} = x$$

$$(x^{1/4})^4 = (x)^4$$

$$x = x^4$$

$$0 = x^4 - x$$

$$0 = x(x^3 - 1)$$

$$x = 0 \text{ and } x = 1$$

The solutions for x are 0 and 1, so the integration limits are a = 0 and b = 1.

Step 3: Determine the function order (if necessary).

Plug any number between the interval [a,b], or [0,1], into each equation to determine which equation yields the larger number. The equation that yields the larger number will be f(x), which is the first equation input. The equation that yields the smaller number will be g(x), which is the second equation input. If a graph was used, the function furthest from the axis of revolution will be f(x).

$$\text{Let } x = 0.5$$

$$y = x^{1/4}$$

$$y = x$$

$$y = (0.5)^{1/4}$$

$$y = 0.5$$

$$y \approx 0.841$$

The first equation, $y = x^{1/4}$, will be f(x) because 0.841 is larger than 0.5. This also means that g(x) will be $y = x$.

Step 4: Plug the function(s) and limits into the integration equation.

$$V = \pi \int_0^1 (x^{1/4})^2 - x^2 \, dx$$

Step 5: Solve the integral.

One of the exponents can be simplified.

$$V = \pi \int_0^1 (x^{1/2} - x^2) \, dx$$

Integrate each term.

$$V = \pi \left[\frac{2}{3} x^{3/2} - \frac{1}{3} x^3 \right]_0^1$$

Solve the definite integral by substituting the integral limits (a and b) for x and subtracting them.

$$V = \pi \left[\left(\frac{2}{3} (1)^{3/2} - \frac{1}{3} (1)^3 \right) - \left(\frac{2}{3} (0)^{3/2} - \frac{1}{3} (0)^3 \right) \right]$$

$$V = \pi \left[\left(\frac{2}{3} - \frac{1}{3} \right) - (0) \right]$$

$$V = \pi \left(\frac{1}{3} \right)$$

Solution: $V = \frac{\pi}{3}$

The Shell Method

The shell method involves finding the volume of a solid by cutting it into cylindrical shells. These equations are based on the curved surface area of a cylinder equation, $A = 2\pi rh$. The table below provides a summary of the equations for the shell method.

Method	Axis of Revolution	Volume (V) Integration Equation
Shell	x-axis	$V_s = 2\pi \int_c^d y[f(y)] dy$ OR $V_s = 2\pi \int_c^d y[f(y) - g(y)] dy$
	y = n	$V_s = 2\pi \int_c^d (n - y)[f(y)] dy$ OR $V_s = 2\pi \int_c^d (n - y)[f(y) - g(y)] dy$
	y = -n	$V_s = 2\pi \int_c^d (y + n)[f(y)] dy$ OR $V_s = 2\pi \int_c^d (y + n)[f(y) - g(y)] dy$
	y-axis	$V_s = 2\pi \int_a^b x[f(x)] dx$ OR $V_s = 2\pi \int_a^b x[f(x) - g(x)] dx$
	x = n	$V_s = 2\pi \int_a^b (n - x)[f(x)] dx$ OR $V_s = 2\pi \int_a^b (n - x)[f(x) - g(x)] dx$
	x = -n	$V_s = 2\pi \int_a^b (x + n)[f(x)] dx$ OR $V_s = 2\pi \int_a^b (x + n)[f(x) - g(x)] dx$

Example 2

Find the volume of the solid generated by revolving the area bounded by the following equations about the x-axis using the shell method.

$$y = x^{1/4}, y = x$$

Step 1: Identify the required integration equation.

When the shell method is used with the x-axis as the axis of revolution, the function variable is y and the integral's upper and lower limits will be "c" and "d." Two equations were provided, so use the following equation from the table.

$$V_s = 2\pi \int_c^d y[f(y) - g(y)] dy$$

Rearrange the equations algebraically so that y is the function variable.

$$y = x^{1/4} \qquad y = x$$

$$(y)^4 = (x^{1/4})^4 \qquad x = y$$

$$y^4 = x$$

$$x = y^4$$

Step 2: Find the upper and lower integration limits.

The smaller limit will be "c" and the larger limit will be "d." Use a graphing calculator to locate the intersection points or set the two equations equal to each other to find where the two graphs intersect.

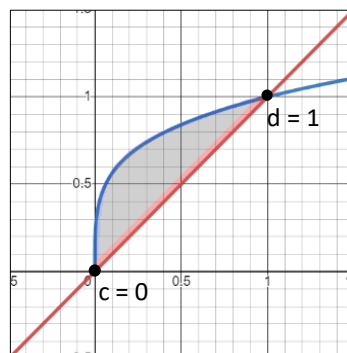

$$y^4 = y$$

$$y^4 - y = 0$$

$$y(y^3 - 1) = 0$$

$$y = 0 \text{ and } y = 1$$

The solutions for y are 0 and 1, so the integration limits are c = 0 and d = 1.

Step 3: Determine the function order (if necessary).

Plug any number between the interval $[c,d]$, or $[0,1]$, into each equation to determine which equation yields the larger number. The equation that yields the larger number will be $f(y)$, which is the first equation input. The equation that yields the smaller number will be $g(y)$, which is the second equation input. If a graph was used, the function furthest from the axis of revolution will be $f(y)$.

Let $y = 0.5$

$$x = y^4 \qquad x = y$$

$$x = (0.5)^4 \qquad x = 0.5$$

$$x \approx 0.0625$$

The second question, $x = y$, will be $f(y)$ because 0.5 is larger than 0.0625. This also means that $g(y)$ will be $x = y^4$.

Step 4: Plug the function(s) and limits into the integration equation.

$$V = 2\pi \int_0^1 y[(y) - (y^4)] dy$$

Step 5: Solve the integral.

Distribute y to simplify.

$$V = 2\pi \int_0^1 y[(y) - (y^4)] dy$$

$$V = 2\pi \int_0^1 y^2 - y^5 dy$$

Integrate each term.

$$V = 2\pi \left[\frac{1}{3}y^3 - \frac{1}{6}y^6 \right]_0^1$$

Solve the definite integral by substituting the integral limits (c and d) for y and subtracting them.

$$V = 2\pi \left[\left(\frac{1}{3}(1)^3 - \frac{1}{6}(1)^6 \right) - \left(\frac{1}{3}(0)^3 - \frac{1}{6}(0)^6 \right) \right]$$

$$V = 2\pi \left[\left(\frac{1}{3} - \frac{1}{6} \right) - (0) \right]$$

$$V = 2\pi \left(\frac{1}{6} \right) = \frac{2\pi}{6} = \frac{\pi}{3}$$

Solution: $V = \frac{\pi}{3}$

Note: This is the same answer as the example for the disk/washer method. The volume of the three-dimensional shape is the same regardless of which method is used.

The Academic Center for Excellence (ACE) offers free on-campus and online tutoring appointments and drop-in services for calculus. For further assistance, please call ACE at (540) 891-3017 or email us at ACE@germanna.edu.

Practice:

1. Find the volume of the solid generated by revolving the area bounded by the following about the x-axis using the disk/washer and shell methods.

$$y = \sqrt{x}, y = \frac{1}{2}x$$

2. Find the volume of the solid generated by revolving the area bounded by the following about the y-axis using the disk/washer and shell methods.

$$y = 6 - x, y = 3, x = 0$$

3. Find the volume of the solid generated by revolving the area bounded by the following about the line $y = -1$ using the disk/washer and shell methods.

$$y = x, x = 4, y = 0$$

Solutions:

1. $V = \frac{8\pi}{3}$

2. $V = 9\pi$

3. $V = \frac{112\pi}{3}$